





WASAET ALNQIL

 Call us

 CUSTOMERS SUPPORT :
00 966 53 2805548

 TECHNICAL SUPPORT :
00 966 55 2778146

 SALES :
00 966 50 8516850

شركة مصنع وسائط النقل للمنتجات المعدنية

حاوية 20 ياردة

CONTAINER 20 YARD

Company of Wasaet Alnaqil Factory For Metal Industries

رؤية
VISION
2030

مصنع وسائط النقل للمنتجات المعدنية تم تأسيسه عام 2011 م في مدينة الرياض متخصص في صناعات الحاويات والمكابس والتوانك ذات جودة ومواصفات عالمية

 SAUDI
MADE

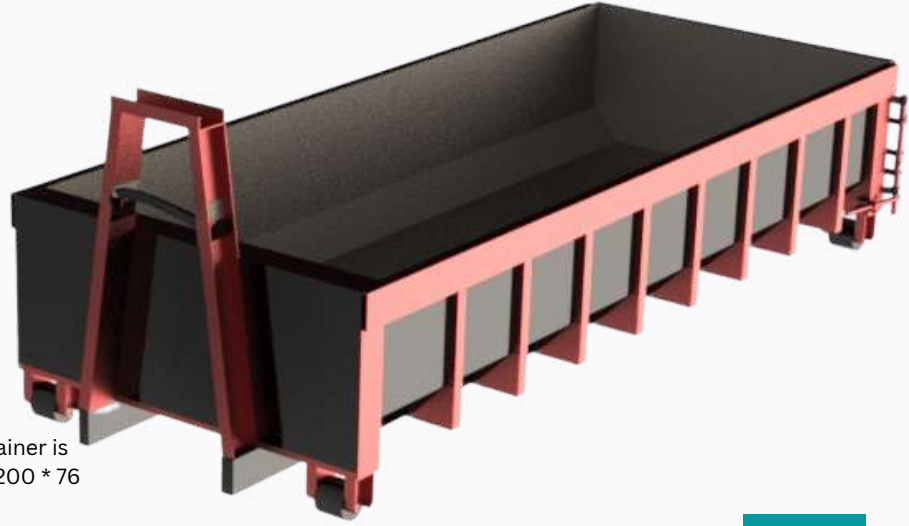

The sides of the container are made of 4 mm, SABIC steel conforms to standard specifications.



The floor of the container is made of 5mm, SABIC steel conforms to standard specifications.



The container is provided with channel beams (160* 64 * 8 mm) on the sides.



The structure of the container is made of channel beams (200 * 76 * 9 mm).



The container is provided with channel beams (75 * 40 * 4 mm) at the bottom of the floor.



The container door is equipped with high-quality hinges with a thickness of (16-20 mm) and channel support (160*64*6mm).



Side hooks for attaching the sail.



The container is equipped with a round hook (55 mm) for lifting.



Container weight 2000 kg.



The container is equipped with (4) wheels with a sectional area of (8 inches).

المواصفات



صاج الأرضية للحاوية
(5مم) حديد سائب مطابق
للمواصفات القياسية.



صاج الجوانب للحاوية (4مم)
حديد سائب مطابق
للمواصفات القياسية



هيكل الحاوية من دعامات
حديد (200*76*9مم).



الحاوية مزودة بدعامات حديد
(160*64*8) على الجوانب.



باب الحاوية مزود بمفصلات عالية
الجودة بسماكة (16-20مم)
ودعامات حديد (160*64*6 مم)



الحاوية مزودة بدعامات حديد
(75*40*4مم) اسفل الارضية.



الحاوية مزودة بهوك من
مبروم سماكة (55 مم).



خطافات جانبية لربط
الشراع



وزن الحاوية 2000 كيلو غرام .



الحاوية مزودة بعدد (4) عجلات
بمساحة مقطع (8 بوصة).



الدهان :

- (free logo)
- (الشعار مجاني) -
- طبقتين نهائي فقط
- (طبقة أساسي +طبقتين نهائي)



STATIC STRUCTURAL

Total deformation
 Type :total deformation
 Unit: mm
 load 15 TON

.

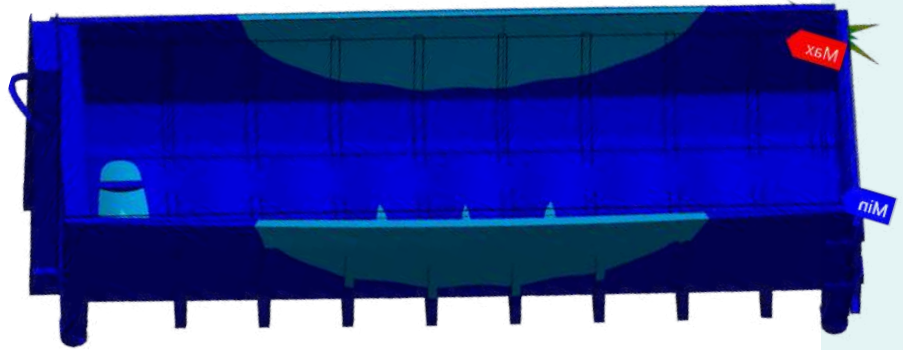
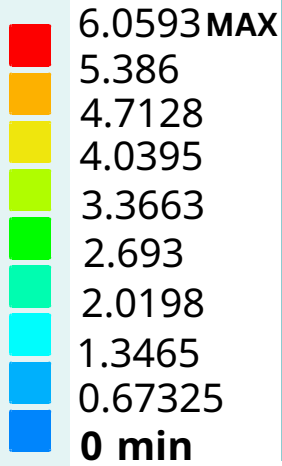

Total deformation
 Type :total deformation
 Unit: mm
 load 15 TON

.

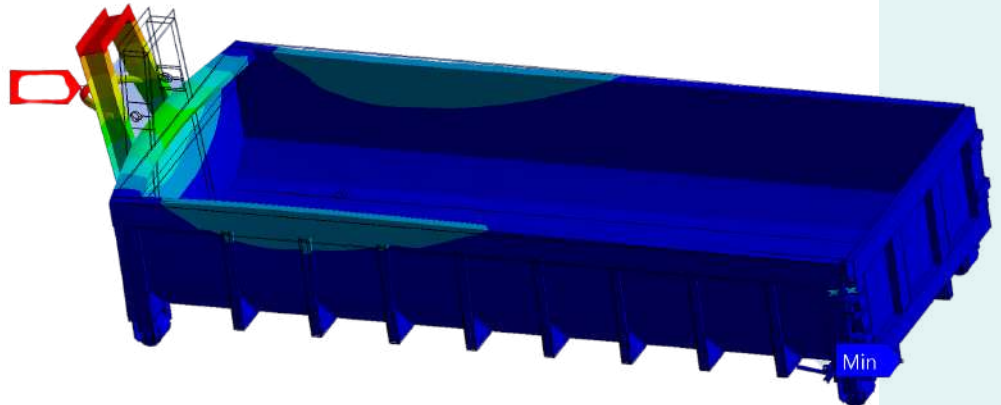
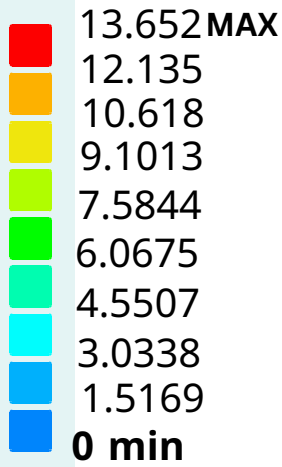

Total deformation
 Type :total deformation
 Unit: mm
 load 15 TON

.

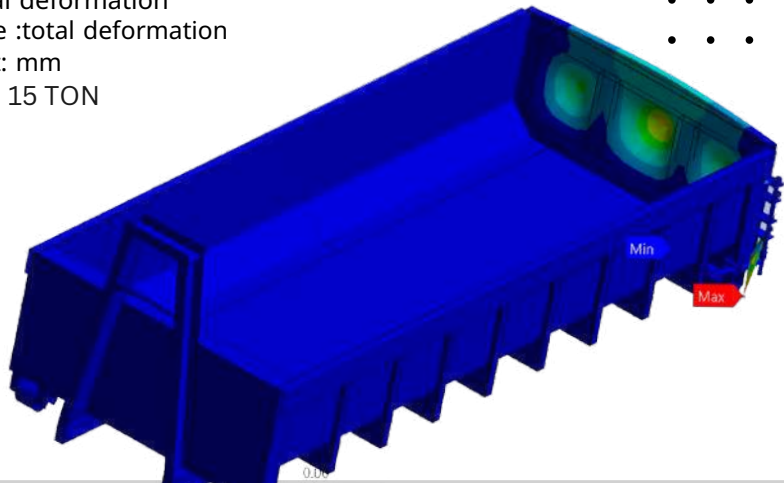
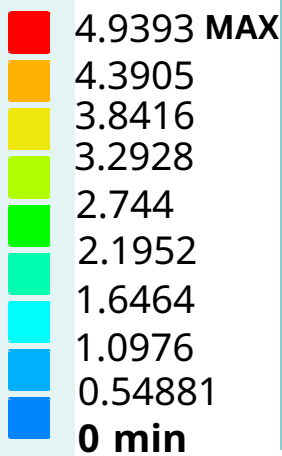

DIMENSIONS

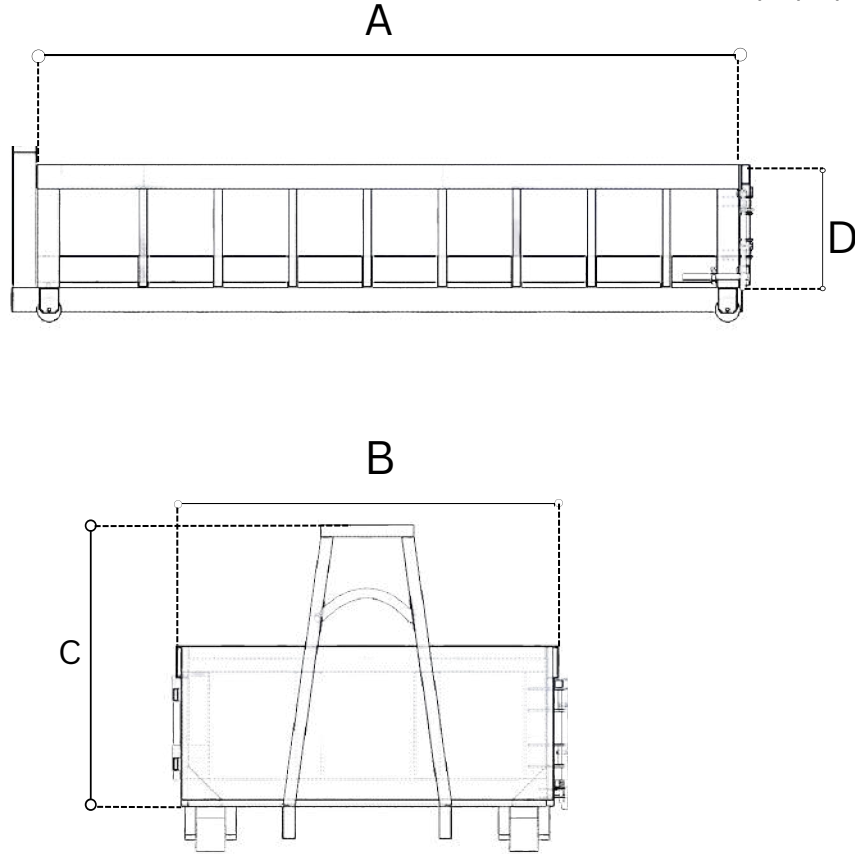

المواصفات و المقاسات الخاصة
حسب الكمية

SYMPOLS	A	B	C	D
20 YARDS	5750	2330	2000	1205
19 YARDS	5500	2330	2000	1205
17 YARDS	5000	2330	2000	1205

Specifications and
special sizes according
to the quantity

شكرا" لاختياركم منتجاتنا THANK YOU

شركه مصنع وسائط النقل للمنتجات المعدنية



LOCATION

Second industrial city - Riyadh - Saudi Arabia



CALL US

 customers support : 00 966 53 2805548

 technical support : 00 966 55 2778146

 sales : 00 966 50 8516850



Website

www.wasaetalnqil.com



WASAET ALNQIL
SOCIAL MEDIA